



CLADDING TECHNOLOGY SHANXI CO., LTD

HTTP://CLADDING.COM.CN TEL:+86-17600050068

Supplementary instructions

Flanges acc. to DIN - EN - ASME - JIS

Technical data





1 Product description

1.1 Specifications

The described flanges are threaded flanges with seal ledge and are available with G 1 or G 1½ inner thread.

The specifications in these supplementary instructions refer to flanges made of 316L. Material 316L corresponds to 1.4404 or 1.4435.

The flanges are available in different versions acc. to the following standards:

DIN - German National Standards Institute (DIN 2501)

EN - European Standard (EN 1092-1)

ASME - American Society of Mechanical Engineers (ANSI B 16.5)

JIS - Japanese Industrial Standard (B 2210-1984)



2 Dimensions

2.1 DIN flanges (DIN 2501)

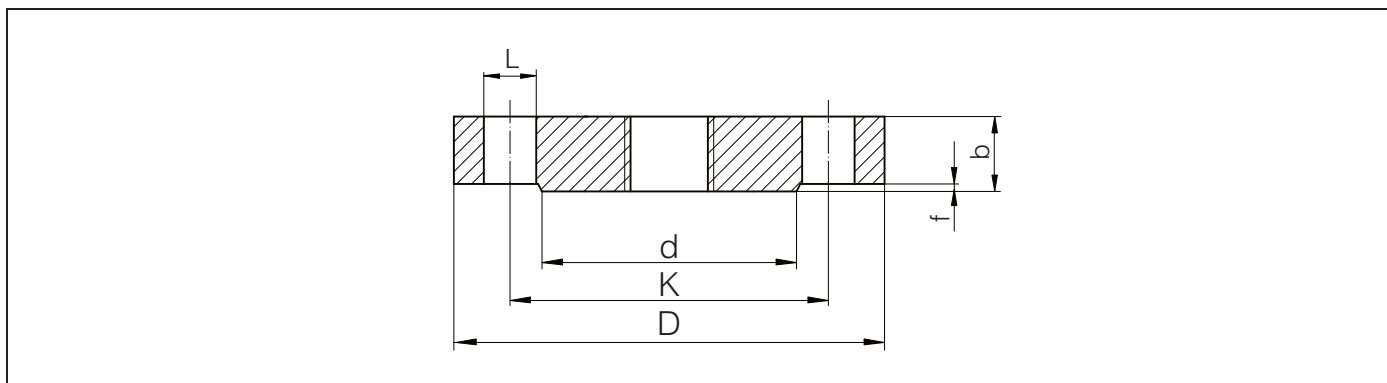

Fig. 1: Dimensions - DIN flange DIN 2501 (seal ledge DIN 2526 form C)

- L Diameter of holes (number of holes)
- d Seal ledge diameter
- K Diameter of hole circle
- D Flange diameter
- b Total flange thickness
- f Seal ledge height

PN10

DN	D	b	K	d	f	L	~kg
25	115	16	85	68	2	4xø14	1,23
32	140	16	100	78	2	4xø18	1,80
40	150	16	110	88	3	4xø18	2,09
50	165	18	125	102	3	4xø18	2,88
65	185	18	145	122	3	4xø18	3,66
80	200	20	160	138	3	8xø18	4,83
100	220	20	180	158	3	8xø18	5,75
125	250	22	210	188	3	8xø18	8,59
150	285	22	240	212	3	8xø22	10,6
175	316	24	270	242	3	8xø22	14,3
200	340	24	295	268	3	8xø22	16,9
250	395	26	350	320	3	12xø22	24,7
300	445	26	400	370	4	12xø22	31,9

Fig. 2: Dimensions - DIN flange PN 10

**PN16**

DN	D	b	K	d	f	L	~kg
25	115	16	85	68	2	4xø14	1,23
32	140	16	100	78	2	4xø18	1,80
40	150	16	110	88	3	4xø18	2,09
50	165	18	125	102	3	4xø18	2,88
65	185	18	145	122	3	4xø18	3,66
80	200	20	160	138	3	8xø18	4,83
100	220	20	180	158	3	8xø18	5,75
125	250	22	210	188	3	8xø18	8,59
150	285	22	240	212	3	8xø22	10,6
175	316	24	270	242	3	8xø22	14,3
200	340	24	295	268	3	12xø22	16,5
250	405	26	355	320	3	12xø26	25,6
300	460	28	410	378	4	12xø26	36,1

Fig. 3: Dimensions - DIN flange PN 16

PN25

DN	D	b	K	d	f	L	~kg
25	115	18	85	68	2	4xø14	1,38
32	140	18	100	78	2	4xø18	2,03
40	150	18	100	88	3	4xø18	2,35
50	165	20	125	102	3	4xø18	3,20
65	185	22	145	122	3	8xø18	4,33
80	200	24	160	138	3	8xø18	5,94
100	235	24	190	162	3	8xø22	7,64
125	270	26	220	188	3	8xø26	11,0
150	300	28	250	218	3	8xø26	14,7
175	330	28	280	248	3	12xø26	17,6
200	360	30	310	278	3	12xø26	22,7
250	425	32	370	335	3	16xø30	34,2
300	485	34	430	395	4	16xø30	47,3

Fig. 4: Dimensions - DIN flange PN 25

**PN40**

DN	D	b	K	d	f	L	~kg
25	115	18	85	68	2	4xø14	1,38
32	140	18	100	78	2	4xø18	2,03
40	150	18	110	88	3	4xø18	2,35
50	165	20	125	102	3	4xø18	3,20
65	185	22	145	122	3	8xø18	4,33
80	200	24	160	138	3	8xø18	5,94
100	235	24	190	162	3	8xø22	7,64
125	270	26	220	188	3	8xø26	11,0
150	300	28	250	218	3	8xø26	14,7
175	350	32	295	260	3	12xø30	22,4
200	375	34	320	285	3	12xø30	27,6
250	450	38	385	345	3	12xø33	44,5
300	515	42	450	410	4	16xø33	64,3

*Fig. 5: Dimensions - DIN flange PN 40***PN64**

DN	D	b	K	d	f	L	~kg
25	140	24	100	68	2	4xø18	2,65
32	155	24	110	78	2	4xø22	3,24
40	170	26	125	88	3	4xø22	4,09
50	180	26	135	102	3	4xø22	4,51
65	205	26	160	122	3	8xø22	5,71
80	215	28	170	138	3	8xø22	6,92
100	250	30	200	162	3	8xø26	10,1
125	295	34	240	188	3	8xø30	16,0
150	345	36	280	218	3	8xø33	23,5
175	375	40	310	260	3	12xø33	30,8
200	415	42	345	285	3	12xø36	39,7
250	470	46	400	345	3	12xø36	57,4
300	530	52	460	410	4	16xø36	81,0

Fig. 6: Dimensions - DIN flange PN 64



PN100

DN	D	b	K	d	f	L	~kg
25	140	24	100	68	2	4xø18	2,65
32	155	24	110	78	2	4xø22	3,24
40	170	26	125	88	3	4xø22	4,09
50	195	28	145	102	3	4xø26	5,84
65	220	30	170	122	3	8xø26	8,03
80	230	32	180	138	3	8xø26	9,43
100	265	36	210	162	3	8xø30	14,3
125	315	40	250	188	3	8xø33	22,6
150	355	44	290	218	3	12xø33	31,8
175	385	48	320	260	3	12xø33	41,3
200	430	52	360	285	3	12xø36	56,1
250	505	60	430	345	3	12xø39	89,6
300	585	68	500	410	4	16xø42	119

Fig. 7: Dimensions - DIN flange PN 100

2.2 EN flanges (EN 1092-1)

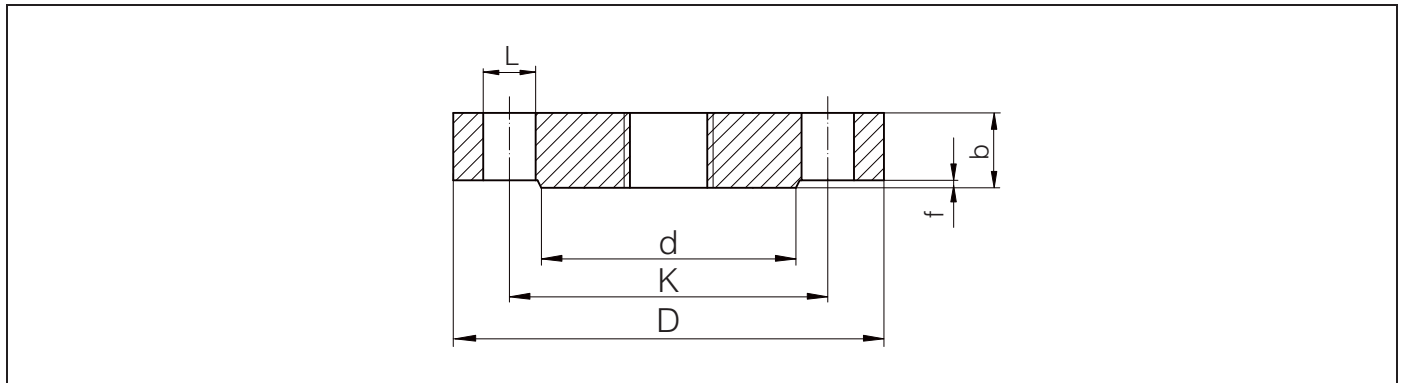

Fig. 8: Dimensions - EN flange EN 1092-1 (seal ledge B1)

- L* Diameter of holes (number of holes)
- d* Seal ledge diameter
- K* Diameter of hole circle
- D* Flange diameter
- b* Total flange thickness
- f* Seal ledge height

**PN16**

DN	D	b	K	d	f	L	~kg
25	115	18	85	68	2	4xø14	1,50
32	140	18	100	78	2	4xø18	2,00
40	150	18	110	88	2	4xø18	2,50
50	165	18	125	102	2	4xø18	2,90
65	185	18	145	122	2	8xø18	3,50
80	200	20	160	138	2	8xø18	4,50
100	220	20	180	158	2	8xø18	5,50
125	250	22	210	188	2	8xø18	8,00
150	285	22	240	212	2	8xø22	10,5
200	340	24	295	268	2	12xø22	16,5
250	405	26	355	320	2	12xø26	25,0
300	460	28	410	378	2	12xø26	35,0

*Fig. 9: Dimensions - EN flange PN 16***PN25**

DN	D	b	K	d	f	L	~kg
25	115	18	85	68	2	4xø14	1,50
32	140	18	100	78	2	4xø18	2,00
40	150	18	100	88	2	4xø18	2,50
50	165	20	125	102	2	4xø18	3,00
65	185	22	145	122	2	8xø18	4,50
80	200	24	160	138	2	8xø18	5,50
100	235	24	190	162	2	8xø22	7,50
125	270	26	220	188	2	8xø26	11,0
150	300	28	250	218	2	8xø26	14,5
200	360	30	310	278	2	12xø26	22,5
250	425	32	370	335	2	12xø30	33,5
300	485	34	430	395	2	16xø30	46,5

Fig. 10: Dimensions - EN flange PN 25

**PN40**

DN	D	b	K	d	f	L	~kg
25	115	18	85	68	2	4xø14	1,50
32	140	18	100	78	2	4xø18	2,00
40	150	18	110	88	2	4xø18	2,50
50	165	20	125	102	2	4xø18	3,00
65	185	22	145	122	2	8xø18	4,50
80	200	24	160	138	2	8xø18	5,50
100	235	24	190	162	2	8xø22	7,50
125	270	26	220	188	2	8xø26	11,0
150	300	28	250	218	2	8xø26	14,5
200	375	36	320	285	2	12xø30	29,0
250	450	38	385	345	2	12xø33	44,5
300	515	42	450	410	2	16xø33	64,0

Fig. 11: Dimensions - EN flange PN 40

PN63

DN	D	b	K	d	f	L	~kg
25	140	24	100	68	2	4xø18	2,50
32	155	24	110	78	2	4xø22	3,50
40	170	26	125	88	2	4xø22	4,50
50	180	26	135	102	2	4xø22	5,00
65	205	26	160	122	2	8xø22	6,00
80	215	28	170	138	2	8xø22	7,50
100	250	30	200	162	2	8xø26	10,5
125	295	34	240	188	2	8xø30	16,5
150	345	36	280	218	2	8xø33	24,5
200	415	42	345	285	2	12xø36	40,5
250	470	46	400	345	2	12xø36	58,0
300	530	52	460	410	2	16xø36	83,5

Fig. 12: Dimensions - EN flange PN 63

**PN100**

DN	D	b	K	d	f	L	~kg
25	140	24	100	68	2	4xø18	2,50
32	155	24	110	78	2	4xø22	3,50
40	170	26	125	88	2	4xø22	4,50
50	195	28	145	102	2	4xø26	6,00
65	220	30	170	122	2	8xø26	8,00
80	230	32	180	138	2	8xø26	9,50
100	265	36	210	162	2	8xø30	14,0
125	315	40	250	188	2	8xø33	22,5
150	355	44	290	218	2	12xø33	30,5
200	430	52	360	285	2	12xø36	54,5
250	505	60	430	345	2	12xø39	87,5
300	585	68	500	410	2	16xø42	131,5

Fig. 13: Dimensions - EN flange PN 100

2.3 ASME flanges (ANSI B 16.5)

Fig. 14: Dimensions - ASME flange ANSI B 16.5 (seal ledge RF)

L Diameter of holes (number of holes)

d Seal ledge diameter

K Diameter of hole circle

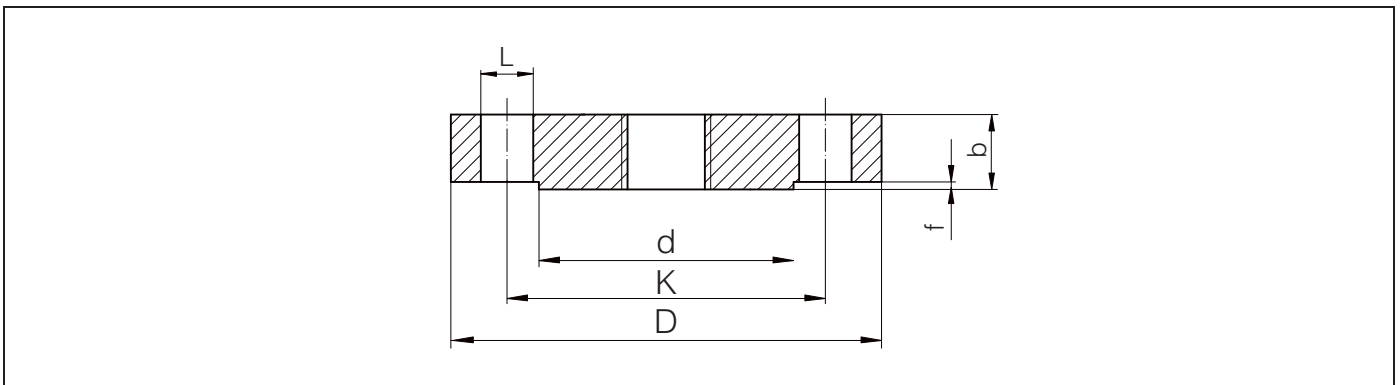
D Flange diameter

b Total flange thickness

f Seal ledge height 150 lb/300 lb: 1.6 mm (0.06 in) or from 600 lb: 6.4 mm (0.25 in)



Class 150

DN	D	b	d	K	L	~kg
1"	108,0	14,2	50,8	79,2	4xø15,7	0,86
1¼"	117,3	15,7	63,5	88,9	4xø15,7	1,17
1½"	127,0	17,5	73,2	98,6	4xø15,7	1,53
2"	152,4	19,1	91,9	120,7	4xø19,1	2,42
2½"	177,8	22,4	104,6	139,7	4xø19,1	3,94
3"	190,5	23,9	127,0	152,4	4xø19,1	4,93
3½"	215,9	23,9	139,7	177,8	8xø19,1	6,17
4"	228,6	23,9	157,2	190,5	8xø19,1	7,00
5"	254,0	23,9	185,7	215,9	8xø22,4	8,63
6"	279,4	25,4	215,9	241,3	8xø22,4	11,3
8"	342,9	28,4	269,7	298,5	8xø22,4	19,6
10"	406,4	30,2	323,8	362,0	12xø25,4	28,8

Fig. 15: Dimensions - ASME flange Class 150

Class 300

DN	D	b	d	K	L	~kg
1"	124,0	17,5	50,8	88,9	4xø19,1	1,39
1¼"	133,4	19,1	63,5	98,6	4xø19,1	1,79
1½"	155,4	20,6	73,2	114,3	4xø22,4	2,66
2"	165,1	22,4	91,9	127,0	8xø19,1	3,18
2½"	190,5	25,4	104,6	149,4	8xø22,4	4,85
3"	209,5	28,4	127,0	168,1	8xø22,4	6,81
3½"	228,6	30,2	139,7	184,2	8xø22,4	8,71
4"	254,0	31,8	157,2	200,2	8xø22,4	11,5
5"	279,4	35,1	185,7	235,0	8xø22,4	15,6
6"	317,5	36,6	215,9	269,7	12xø22,4	20,9
8"	381,0	41,1	269,7	330,2	12xø25,4	34,3
10"	444,5	47,8	323,8	387,4	16xø28,4	53,3

Fig. 16: Dimensions - ASME flange Class 300

**Class 600**

DN	D	b	d	K	L	~kg
1"	124,0	17,5	50,8	88,9	4xø19,1	1,60
1¼"	133,4	20,6	63,5	98,6	4xø19,1	2,23
1½"	155,4	22,4	73,2	114,3	4xø22,4	3,25
2"	165,1	25,4	91,9	127,0	8xø19,1	4,15
2½"	190,5	28,4	104,6	149,4	8xø22,4	6,13
3"	209,6	31,8	127,0	168,1	8xø22,4	8,44
3½"	228,6	35,1	139,7	184,2	8xø25,4	11,0
4"	273,1	38,1	157,2	215,9	8xø25,4	17,3
5"	330,2	44,5	185,7	266,7	8xø28,4	29,4
6"	355,6	47,8	215,9	292,1	12xø28,4	36,1
8"	419,1	55,6	269,7	349,3	12xø31,8	58,9
10"	508,0	63,5	323,8	431,8	16xø35,1	97,5

Fig. 17: Dimensions - ASME flange Class 600

Class 900

DN	D	b	d	K	L	~kg
1"	149,4	28,4	50,8	101,6	4xø25,4	3,57
1¼"	158,8	28,4	63,5	111,3	4xø25,4	4,14
1½"	177,8	31,8	73,2	124,0	4xø28,4	5,75
2"	215,9	38,1	91,9	165,1	8xø25,4	10,1
2½"	244,4	41,1	104,6	190,5	8xø28,4	14,0
3"	241,3	38,1	127,0	190,5	8xø25,4	13,1
4"	292,1	44,5	157,2	235,0	8xø31,8	26,9
5"	349,3	50,8	185,7	279,4	8xø35,1	36,5
6"	381,0	55,6	215,9	317,5	12xø31,8	47,4
8"	469,9	63,5	269,7	393,7	12xø38,1	82,5
10"	546,1	69,9	323,8	469,9	16xø38,1	122,0

Fig. 18: Dimensions - ASME flange Class 900



Class 1500

DN	D	b	d	K	L	~kg
1"	149,4	28,4	50,8	101,6	4xø25,4	3,57
1¼"	158,8	28,4	63,5	111,3	4xø25,4	4,14
1½"	177,8	31,8	73,2	124,0	4xø28,4	5,75
2"	215,9	38,1	91,9	165,1	8xø25,4	10,1
2½"	244,4	41,1	104,6	190,5	8xø28,4	14,0
3"	266,7	47,8	127,0	203,2	8xø31,8	19,1
4"	311,2	53,8	157,2	241,3	8xø35,1	29,9
5"	374,7	73,2	185,7	292,1	8xø41,1	58,4
6"	393,7	82,6	215,9	317,5	12xø38,1	71,8
8"	482,6	91,9	269,7	393,7	12xø44,5	122,0
10"	584,2	108,0	323,8	482,6	12xø50,8	210,0

Fig. 19: Dimensions - ASME flange Class 1500

Class 2500

DN	D	b	d	K	L	~kg
1"	158,8	35,1	50,8	108,0	4xø25,4	4,96
1¼"	184,2	38,1	63,5	130,0	4xø28,4	7,35
1½"	203,2	44,5	73,2	146,1	4xø31,8	10,4
2"	235,0	50,8	91,9	171,5	8xø28,4	15,6
2½"	266,7	57,2	104,6	196,9	8xø31,8	22,6
3"	304,8	66,5	127,0	228,6	8xø35,1	34,8
4"	355,6	76,2	157,2	273,1	8xø41,1	53,9
5"	419,1	91,9	185,7	323,8	8xø47,8	90,8
6"	482,6	108,0	215,9	368,3	8xø53,8	141,0
8"	552,5	127,0	269,7	438,2	12xø53,8	214,0
10"	673,1	165,1	323,8	539,8	12xø66,5	411,0

Fig. 20: Dimensions - ASME flange Class 2500



2.4 JIS flanges (B 2210-1984)

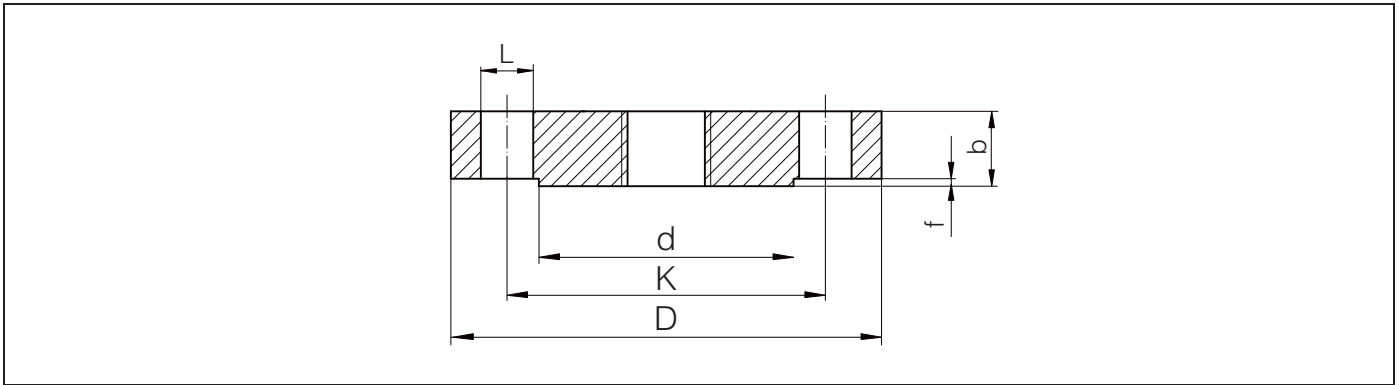

Fig. 21: Dimensions - JIS flange (Regular Flange)

- L Diameter of holes (number of holes)
- d Seal ledge diameter
- K Diameter of hole circle
- D Flange diameter
- b Total flange thickness
- f Seal ledge height

10 K

DN	D	b	K	d	f	L
25	125	14	90	67	1	4xø19
32	135	16	100	76	2	4xø19
40	140	16	105	81	2	4xø19
50	155	16	120	96	2	4xø19
65	175	18	140	116	2	4xø19
80	185	18	150	126	2	8xø19
100	210	18	175	151	2	8xø19
125	250	20	210	182	2	8xø23
150	280	22	240	212	2	8xø23
200	330	22	290	262	2	12xø23
250	400	24	355	324	2	12xø25
300	445	24	400	368	3	16xø25

Fig. 22: Dimensions - JIS flange 10 K (B 2210 - 1984) Regular Flange



3 Pressure-Temperature-Charts

3.1 Pressure-Temperature-Chart - EN flanges

PN	16	25	40	63	100
RT	16,0	25,0	40,0	63,0	100,0
50°C	15,6	24,4	39,1	61,1	97,8
100°C	14,2	22,2	35,6	56,0	88,9
150°C	12,8	20,0	32,0	50,4	80,0
200°C	11,7	18,3	29,3	46,2	73,3
250°C	10,9	17,0	27,2	42,8	68,0
300°C	10,3	16,1	25,8	40,6	64,4
350°C	9,90	15,4	24,7	38,9	61,8
400°C	9,60	15,0	24,0	37,8	60,0

Fig. 23: Pressure-Temperature-Chart - EN flanges (specifications in bar)

RT Temperature range -10 ... +50°C

3.2 Pressure-Temperature-Chart - ASME flanges

Class	150	300	600	900	1500	2500
RT	15,9	41,4	82,7	124,1	206,8	344,7
50°C	15,3	40,0	80,0	120,1	200,1	333,5
100°C	13,3	34,8	69,6	104,4	173,9	289,9
150°C	12,0	31,4	62,8	94,2	157,0	261,6
200°C	11,2	29,2	58,3	87,5	145,8	243,0
250°C	10,5	27,5	54,9	82,4	137,3	228,9
300°C	10,0	26,1	52,1	78,2	130,3	217,2
325°C	9,30	25,5	51,0	76,4	127,4	212,3
350°C	8,40	25,1	50,1	75,2	125,4	208,9
375°C	7,40	24,8	49,5	74,3	123,8	206,3
400°C	6,50	24,3	48,6	72,9	121,5	202,5

Fig. 24: Pressure-Temperature-Chart - ASME flanges (specifications in bar)

RT Temperature range -29 ... +38°C